

EX9530

The EX-9530 converter is an intelligent, stackable expansion module which can be connected to a PC's USB port or a USB Hub. The modules provide a High-Speed RS-232/RS-422 or RS-485 serial port with jumperless auto baud rate detection ("**AutoPro**"). The EX-9530 offers easy connectivity to traditional serial devices.

The RS-232 standard supports full-duplex communication and handshaking signals (such as RTS, CTS). The RS-485 controller is completely transparent to the user and the software is written to work with half-duplex on the COM port without any modification.

The EX-9530's opto-isolation provides 3000 VDC isolation to protect the host computer from ground loops and destructive voltage spikes on the RS-232/RS-422 and RS-485 data lines.

EX-9530 also offers internal surge-protection on its data lines. Internal high-speed transient suppression on each data line protects the module from dangerous voltage levels or spikes.



Features

- USB Specification 1.1 Compliant
- Auto direction flow control on RS-485
- Full-Duplex RS-232/RS-422 support
- RS-232 support RTS & CTS handshake signals
- Minimum 3000 VDC isolation protection
- Transient suppression on RS-485 data lines
- Auto switching for USB to RS-232/RS-422 or RS-485
- Auto Switching Baud Rate up to 115.2 Kbps
- Reserved space for termination resistors R1(TX/DATA), R2(RX)
- Power and data flow indicator for troubleshooting
- Driver support for Windows 95/98/ME/2000/XP, Linux
- Power requirement: Self Power

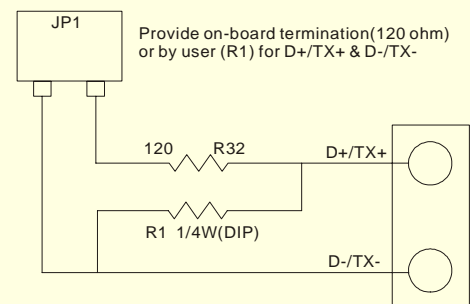

Termination Resistor "R1" for D+/TX+ & D-/TX-

Termination Resistor "R2" for RX+ & RX-

If the length of RS-485 is about 1.2KM, try 120 ohm first.

If the length of RS-485 is about 600M, try 220 ohm first.

If the length of RS-485 is about 300M, try 330 ohm first.

Block diagram:

